

7807 Noz-L-Jet® Fogger

PARTS PRICE LIST & ORDER FORM

1. Select parts (see drawing over) and quantities. Shipping costs and sales taxes if applicable will be added to order subtotal.
2. Enter "Ship To Information" [physical locations only]. An email address is required for confirmation and tracking information.
3. Specify payment method. If credit/debit card, include Authorization (ADM-004).
4. Send to Fogmaster by: a) Fax: 1.954.480.8563; b) Scan & email: info@fogmaster.com; or c) Postal mail (address below).

NOTE: Motors and motor parts are listed on a separate page.

KITS & ASSEMBLIES

(see other side for individual parts)

Qty.	Dwg. Ref.	Kit No.	Description	Price	Qty.	Dwg. Ref.	Kit No.	Description	Price
___	1,2,3	049B4	Tank w/ 4 Clamps	\$ 83.00	___	40,41,42,43	462	Hose & Wand Assm (Short)	\$ 196.00
___	2,3	205	Tank Clamp (1)/Rivets	4.50	___	45,46,49,60 61,62,63,64 66,71,74 75,77,78			
___	7,8,9,13	051	Screen/Wt. Assm 5"	7.30	___	40,41,42,43	463	Hose & Wand Assm (Long)	258.00
___	10,22	052	Coupling Assembly	5.50	___	45,46,49,60 63,64,65,66 69,71,74 75,77,78			
___	10,11,12,22	053A	Couplings (2) & Hdwr.	10.50	___	10,21,22,25/A	461	Front Housing Assm 120V	149.60
___	16,17	206	Housing Hardware (one set of 4)	4.60	___	26,27,28A,29	471	Front Housing Assm 240V	151.70
___	52,53	058	Knob & Mounting Hdwr	3.60	___	36,37,38,48 50,51,52,53,56 72,73,74,76			
___	27,28A	060	Switch Assembly, Gasket & Terminal	8.75	___	5,6,11,12,15 30,31,32,33 34,35	402A	Rear Housing Assm	101.80
___	30,31,32 33,34,35	055	Trunion Hardware (one side)	6.00	___	40,41,42,43 45,46,49,60 61,62,63,64 71	465	Wand Assembly (Short)	149.00
___	25,27,29	011	Cord Set, 120V 9 Ft.	12.25	___	40,41,42,43 45,46,49,60 63,64,65,69 71	466	Wand Assembly (Long)	210.00
___	25A,27,29	012	Cord Set, 240V 9 Ft.	15.00					
___	21,50,51	464	Front Housing w/Adapter	50.20					
___	52,53,47	104	Adjustment Valve (Knob & Hardware)	18.10					
___	36,37,38,39 (or Rivet)	056	Grounding Hardware	2.50					
___	40,41,42,43 45,46	308A	Venturi Assembly	45.00					

See reverse side for individual parts.

1. Order Amount

Product Cost _____

Sales tax (Florida only) _____

Shipping cost _____

Total _____

Sales tax (if applicable) and shipping charges will be added.

2. Contact/Ship To Information

Name _____

Company _____

Address _____

City, State _____

Zip _____ Phone _____

email _____

(Used only to communicate about this order; not for marketing or spam.)

3. Payment Method

- Credit/Debit Card (American Express, MasterCard or Visa only). **Include Authorization form (ADM-004).**
- Check or money order (US customers only). **Call or email us for shipping cost.**



1051 S.W. 30th Ave., Deerfield Beach, FL 33442
 Phone (1) 954.481.9975 • Fax (1) 954.480.8563
 www.fogmaster.com • email: info@fogmaster.com

7807 Noz-L-Jet *(Cont'd)*

INDIVIDUAL PARTS (see other side for kits & assemblies)

Qty.	Dwg. Ref.	Part No.	Description	Price	Qty.	Dwg. Ref.	Part No.	Description	Price
___	4	021	Tank Gasket	\$ 9.80	___	63	470	Toggle Valve	\$ 103.00
___	5	400NJ	Cover Plate, Black	17.60	___	64	472	Adapter (one)	3.00
___	6	401	Trunion Bracket, Black	24.00	___	65	473	Tubing 35"x3/16x5/16	13.10
___	15	202	Rear Housing	39.50	___	66	474	Hose 36" with cuffs	52.00
___	19	022	Torque Ring (one)	6.00	___	69	477	Long Wand	88.20
___	20	023	Motor Gasket (one)	4.00	___	70	081	Intake Filter (1)	11.00
___	23	024	Tube 8"x3/16x5/16	3.90	___	70	080	Intake Filter (10)	82.00
___	24	025	Armour Spring	3.80	___	71	481	Rotor Clip S/S (small)	.80
___	26	026	Strain Relief	2.00	___	72	485	Check Valve	10.50
___	48	219	Tube 5"x3/16x7/16	3.80	___	73	484	Union Connector	6.70
___	49	480	Screw #10 x 3/8	.50	___	74	483	Tube-barb adapter (1 ea)	4.50
___	50	478	1 1/4" Adapter	5.00	___	75	482	SS Clamp with Knob	7.40
___	51	479	Nut 1 1/4"	4.20	___	77	486	Tubing 44"x3/16x7/16	27.40
___	60	467	Front Cuff	9.20	___	78	580	Rotor Clip S/S (large)	.90
___	61	468	Short Wand	47.00	___		900	Tank Liners(10)	5.70
___	62	469	Tube 13"x3/16x5/16	4.20	___		901	Tank Liners (50)	22.00
					___	ft	001	Tubing, 3/16x5/16"	3.90/ft
					___	ft	002	Tubing, 3/16x7/16"	7.90/ft
					___		244	Tubing Repl Kit	14.00

NOZ-L-JET™ FOGGER
MODEL 7807

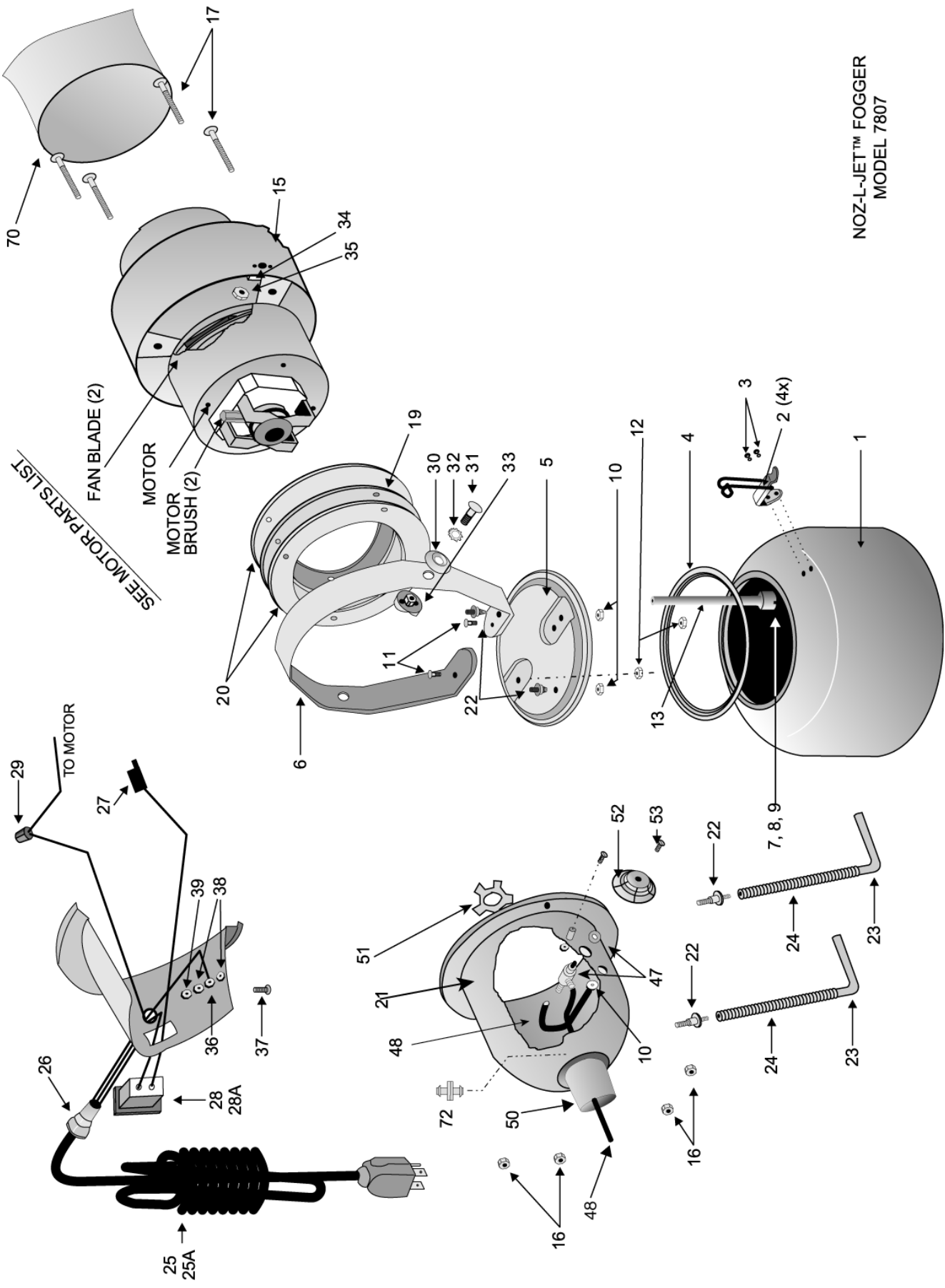

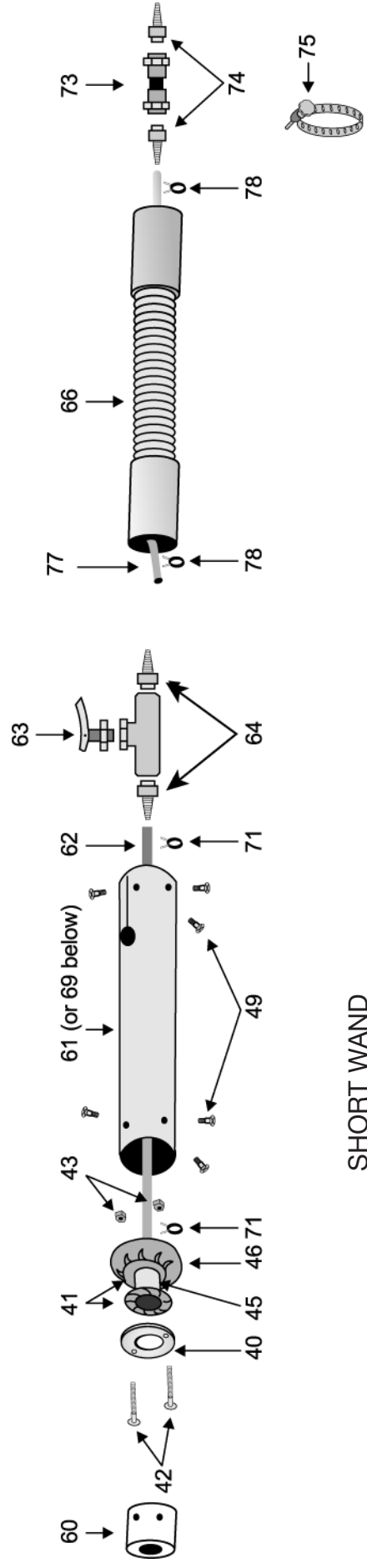

SHORT WAND

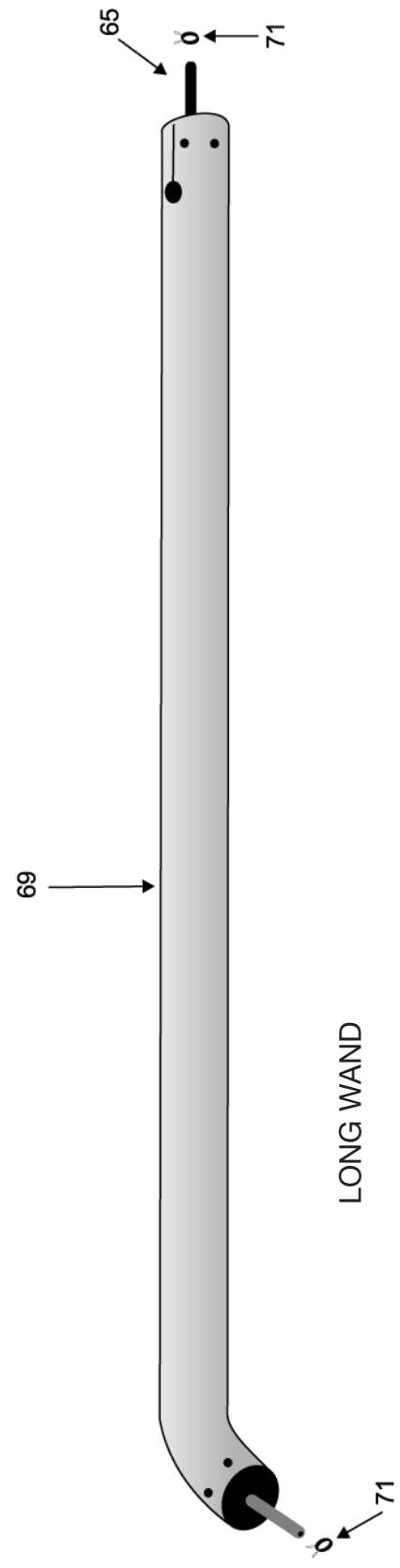

LONG WAND

LONG AND SHORT
WAND ASSEMBLIES FOR
NOZ-L-JET™ FOGGERS
MODEL 7807

Motors & Motor Parts

PARTS PRICE LIST & ORDER FORM

Fogmaster units can be kept functional and useful even though many years old. Should you need parts or repairs, we support you. This sheet covers motors and motor parts. For non-motor items, download the parts list for your model (links are posted at <http://fogmaster.com/support.htm>).

Motors: A replacement motor must match the operating voltage of the old one, but you can choose the number of fan stages and brush design.

Fan Stages: A 1-stage motor has one fan blade. A 2-stage motor has two fan blades and a taller fan enclosure (see drawing on next page).

Motor Brushes: A motor uses two brushes. The motor brush is a wear part; it erodes preferentially to protect the commutator. Brush life is typically 600-650 operating hours but adverse operating conditions or a worn commutator will shorten its life. Motor brushes are not covered by the product warranty.

The MS [Motor Saver™] brush is a drop-in replacement for a standard brush. It is designed to interrupt power when worn out, to protect the commutator from scratching.

The LS motor offers a substantially longer life (2,000 - 2,500 hours), but its brushes are not replaceable.

Motor Kits: A motor kit includes a 1-stage motor, mounting ring and four motor spacers. To replace a 2-stage motor with a 1-stage motor, use the kit.

How to Order Replacements

1. Determine operating voltage of your unit (see nameplate label).
2. Determine the number of fan stages of the existing motor (see graphic, next page).
3. Select brush type. MS brushes or LS motors are recommended for heavy duty applications.
4. Mark items and quantities (next page), and total product cost below.
5. Fill out the Contact/Ship To Information and Payment Method sections below. An email address is required for order confirmation or tracking information.
6. Mail, fax or scan/email order form. We add sales tax (if applicable) and shipping cost to your order. If you are exempt from Florida sales tax, attach certificate.

1. Order Amount

Product Cost	_____	
Sales tax (Florida only)		----
Shipping cost		----
Total		----

Sales tax (if applicable) and shipping charges will be added.

2. Contact/Ship To Information

Name _____
Company _____
Address _____
City, State _____
Zip _____ Phone _____
email _____
(Used only to communicate about this order; not for marketing or spam.)

3. Payment Method

- Credit/Debit Card (American Express, MasterCard or Visa only). **Include Authorization form (ADM-004).**
- Check or money order (US customers only). **Call or email us for shipping cost.**



1051 S.W. 30th Ave., Deerfield Beach, FL 33442
Phone (1) 954.481.9975 • Fax (1) 954.480.8563
www.fogmaster.com • email: info@fogmaster.com

FAN STAGES

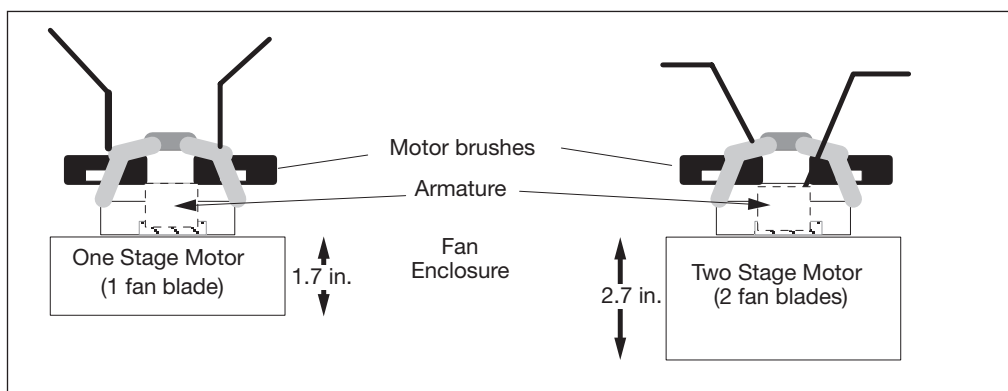

MOTORS, KITS & PARTS

Qty.	Part No.	Description	Price	Qty.	Part No.	Description	Price
___	115	Motor, Std brush, 1 Stage, 120 V	\$ 106.00	___	213CB	Motor, LS design, 2 stage, 120 V	\$ 188.00
___	125	Motor, Std brush, 1 Stage, 240 V	115.00	___	223CB	Motor, LS design, 2 stage, 240 V	188.00
___	213	Motor, Std brush, 2 Stage, 120 V	119.00	___	215	Motor Kit, Std brush, 1 Stage, 120 V	110.00
___	223	Motor, Std brush, 2 Stage, 240 V	132.00	___	225	Motor Kit, Std brush, 1 Stage, 240 V	119.00
___	213MS	Motor, MS brush, 2 Stage, 120 V	144.00	___	040	Fan blade	16.00
___	223MS	Motor, MS brush, 2 Stage, 240 V	149.00				

REPLACEMENT BRUSHES

Qty.	Part No.	Description	Price	Qty.	Part No.	Description	Price
		<i>For One Stage Motors</i>				<i>For Two Stage Motors</i>	
___	030	Std. Brush (pair), 120 V	\$ 18.00	___	033	MS Brush, set (1 MS, 1 std), 120 V	\$ 33.00
___	032	Std. Brush (pair), 240 V	18.50	___	034	MS Brush, set (1 MS, 1 std), 240 V	34.40

CREDIT/DEBIT CARD AUTHORIZATION

I authorize The Fogmaster Corporation to charge the following credit/debit card for goods ordered, applicable taxes and shipping costs. If any duties, VAT or import fees for my order are backcharged to Fogmaster, I authorize Fogmaster to charge them against this card.

Card Holder Name: _____

Card Billing Address: _____

City, State: _____

Country, Zip/Postal Code: _____

Card Type: ___ American Express ___ MasterCard ___ Visa

Card Number.: _____

Expiration Date: _____

Security Code (CCV): _____ (Amex: 4 digits on front of card) (Visa/MC: 3 digits on back of card)

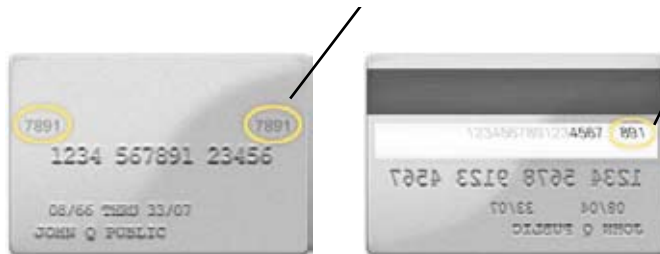

Authorization: ___ Use for this transaction only [SO# or Date _____].
 ___ Keep authorization on file for future orders.
 ___ Use only for backup payment of account balance.

(Date)

(Signature)

(Print Name)

NOTE: Any credit due will be issued to the card used for the original purchase. Credits to a debit card may take 1-2 weeks to clear. This is due to the policies of the issuing bank, not Fogmaster.

(Return to Fogmaster by: mail; fax 1.954.480.8563; or scan/email to info@fogmaster.com.)

(FMC Use)

Received _____ by _____ SO / Quotation: _____

